

“V” Roll Test Bench

MAC's standard test bench utilizes 120 degree "V" rolls and pinch stands to support and position the test material. The fixed bottom "V" rolls, in conjunction with a flat top roll, provide 3 points of contact and ensure firm support for the test material, eliminating vibration that can cause false indications.

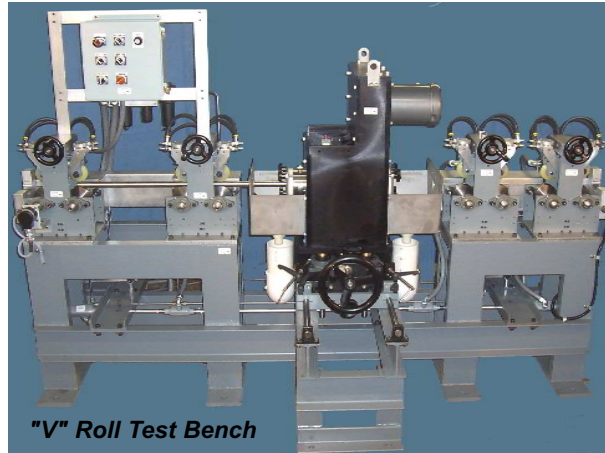

90 degree rolls are also available for square material. Individual elevating platforms are usually included on the test bench for positioning larger rotary mechanics.

Auto diameter controls are available to automate adjustments of the testers and drives when the test material diameter is changed.



“V” Roll Pinch Stands

Automated or manual controls adjust the pinch stand rolls to the size of the test material. Drive Mechanisms provide forward movement of the test material through the coil platforms and rotary mechanics where needed.

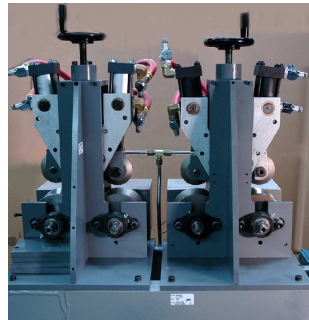

Pinch stands also ensure that the test material is properly positioned as it enters and leaves the test sensors. They can be mounted on a test bench or directly on a production line.

Automated or manual Pinch Stands help eliminate vibration that can interfere with the test.

There are two or four dual Pinches for ensuring proper centering of the material through the tester mounted on a weldment. Each pinch must be individually set up.



Drawing of "V" Roll Test Bench

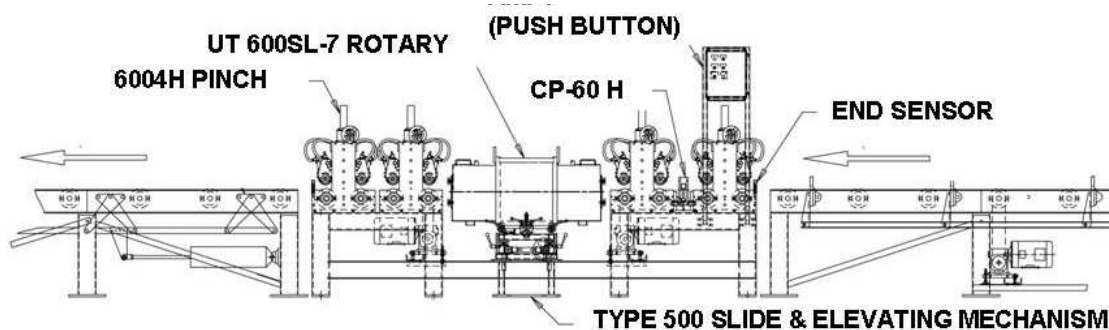

- The 4 V rolls, 4 Pinches, and rolls are air or spring operated
- Center line is 33.04" or 35.75" from the floor
- Constant base

Size Ranges:

- 1500
- 3500
- 6000
- 7500
- 16000



Constant Center Test Bench



A constant center triple drive roll bench is another option for mounting the various mechanical components for MAC test systems. The entire bench is adjustable and eliminates vibrations from the test material that can cause false reject signals.

Constant center benches are often used when testing products such as tubes with badly formed ends, upset pipe or difficult straightening applications. The encoder speed stays the same for any roll size and the 12 rolls are fixed center.



Triple Pinch Stands

A triple pinch is mounted between each test station on the bench. Each pinch, driven by a separate AC motor, uses three hardened steel rolls to center the test material. A frequency converter controls the AC motors to guarantee equal speed for all of the pinches. Slide mechanisms are available to allow access to test heads for off line setup and maintenance.

The entire bench can be adjusted up and down to align the test coils and heads with the level of the incoming test material. Adjusting the bench height and the opening of the triple pinches for changes in test material dimension is accomplished automatically through the PLC or Conductor controls.



Triple Pinch Rolls

The Triple Pinches guarantee a controlled entrance and exit from the test stations and need no manual settings when dimensions are changed. There is no standard centerline measurement.



Drawing of Triple Test Bench

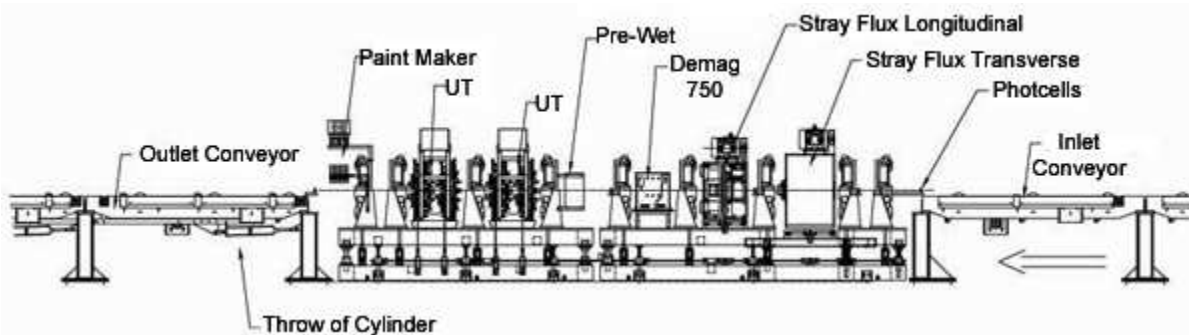

Size Ranges:

- The 160 and 220 mm benches are designed to handle both tubes and bars
- The 125 mm is designed for tube testing

Additional sizes are available upon request