

FLAW DETECTION USING ULTRASONIC TEST TECHNIQUES

PRINCIPLES OF OPERATION

Ultrasonic inspection can be used to detect surface flaws such as cracks and internal flaws such as voids or inclusions of foreign material. It is also commonly used to measure wall thickness in tubes and can measure diameters of bars. Two methods are used for flaw detection - the through-transmission and the pulse-echo method. In the through-transmission test method, two transducers are used, one as a transmitter and the other as a receiver. The two transducers are located on opposite sides of the test part.

PULSE-ECHO TECHNIQUE

When using the more popular pulse-echo method, one transducer serves as both a transmitter and receiver. This presents an advantage by itself, but the main advantage is that the test can be conducted even when there is access to only one side of the material under test.

In ultrasonic testing a coupling medium of liquid or solid material between the transducer and the test part is necessary. Ultrasound is a mechanical vibration or pressure wave similar to audible sound. The only difference is that the pitch or the frequency of the vibration is much higher. Audible sounds cover the range of 30 Hz to 15kHz. Vibrations above 15 kHz are generally referred to as ultrasound, but for nondestructive testing the range is usually from 1MHz to 30 MHz or higher. These sound waves can be highly directional and can be focused into a small spot or a thin line depending on the requirements. They can also be limited to a very short duration, which is important for fine longitudinal resolution or accurate thickness measurement.

Figure 1 illustrates the principle of pulse-echo technique. The top part of the figure shows the physical configuration of the test. The transducer produces a pressure wave in response to the electrical pulse which has been applied to it. This is usually referred to as an ultrasonic pulse or initial pulse. The pressure wave travels through the coupling medium, which is usually water, to the test part. At the interface of the coupling

medium and the test part the ultrasonic pulse enters the part but a portion is reflected back to the transducer. After entering the part there is a partial reflection from the internal flaw. The remainder of the pulse travels to the back wall, where another partial reflection and transmission occurs. The lower part of Figure 1. shows the electrical signals as a function of time, referenced to the locations of the transducer and the test part with an internal flaw.

Figure 1.

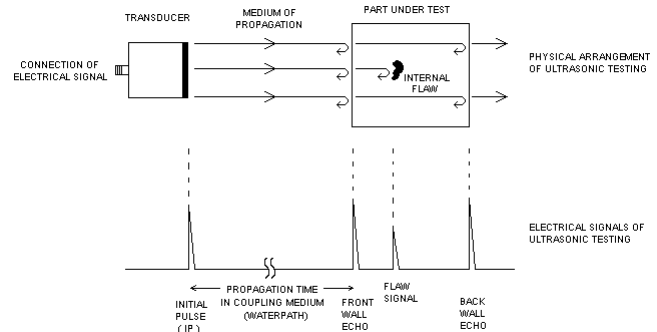

Basic principle of ultrasonic testing by "pulse-echo" method.

The distances in the part and the time segments of the electrical signal are proportional in the same material, but only in the same material, since the sound velocity is material dependent. By calibrating a particular specimen with a given sound velocity, the elapsed time between the front and back surfaces can be easily translated to a measure of thickness. For automatic flaw testing, a gate is placed between the front echo and back echo and if a signal is detected in the gated area it indicates the presence of a flaw. The signal in the gated time window is usually peak detected, producing an analog output that can be recorded for reference purposes.

The test described above uses a longitudinal wave inspection with normal incidence when the ultrasonic beam is perpendicular to the front surface of the test part. This method is used to detect internal flaws, however, it is not well suited for detecting surface flaws such as cracks.

USING SHEAR WAVES

Shear waves are used to detect both surface cracks and internal flaws. In the shear wave the particle motion is perpendicular to the direction of wave propagation, while in the longitudinal wave they coincide. Shear waves are generated from longitudinal waves. When the angle of incidence of an ultrasonic beam is not 90° , refraction occurs and the beam splits into two parts in a solid material: a longitudinal and a shear wave beam. The longitudinal beam has a greater refraction angle than the shear wave. By increasing the angle of incidence at one point, the longitudinal beam ceases to exist and only the shear wave remains. This angle is called the first critical angle.

FLAW DETECTION ON TUBES AND BARS

For flaw detection on tubes and bars, shear wave testing is used. The cross section of a tube is shown on Figure 2. The right hand side of the drawing shows the detection of a crack on the inside surface of the tube. A similar arrangement on the left side shows the geometry of flaw detection on the outside surface of the tube. The shear wave can bounce several times between the I.D. and O.D. surfaces of the tube and any internal flaws in the path of the beam are detected as well. Notice that the right hand transducer produces a shear wave that travels clockwise inside the tube, while the left hand transducer produces a shear wave traveling counter clockwise.

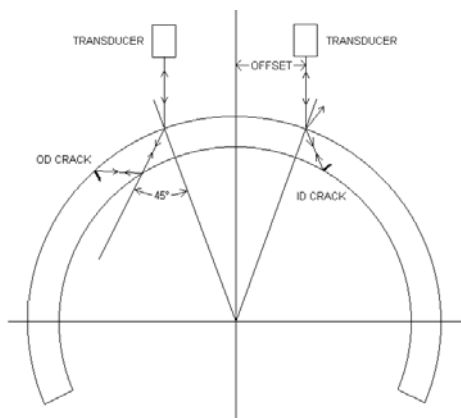

Figure 2.
Tube testing for longitudinal cracks on I.D. and O.D.
by refracted shear-waves.

To assure the most reliable flaw detection both clockwise and counter-clockwise arrangements are used simultaneously. In order to generate a shear wave the transducer is positioned with an offset.

The right amount of offset depends upon the sound velocity in the material of the tube and the sound velocity in the water. The required offset can be calculated using a simple formula or read from a table as a function of the tube diameter and material. With this arrangement, longitudinal cracks can be detected. In order to detect transverse cracks the transducer has to be located over the center of the tube and angled in a plane containing the center line of the tube as shown on Figure 3.

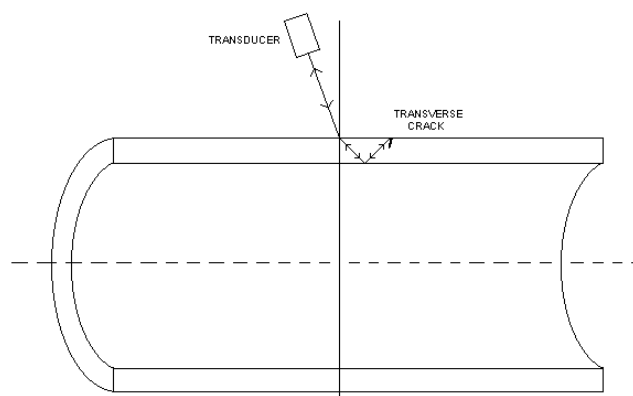

Figure 3.
Detection of transverse cracks on tubes.

The full circumference of the tube can be scanned if it is rotated around the center. The same result can be obtained if the set of transducers is rotated around the same center. By moving the tube along the centerline, a full body test is achieved.

ROTARY ULTRASONIC TESTERS

In the ECHOMAC[®] ROTARY TESTER up to eight transducers are mounted in a rotating chamber. The electrical connections are made through rotary capacitors. The tube is moved through the center of the rotor and the space between the transducers and the tube is filled with water. The rotational speed is between 1800 and 4000 RPM, allowing a testing speed of up to 400 feet per minute.

Ultrasonic inspection allows detection of flaws and measurement of wall thickness simultaneously. In this manner, full-volume testing can be achieved in a five-channel test station. Transducers are oriented for clockwise, counter-clockwise, forward and reverse-looking shear wave test and longitudinal wave wall thickness measurement.

